



Professional Table Assembly Instructions

MODEL X-3-XB, MODEL X-4-XB,
MODEL XI-3-XB, MODEL XI-4-XB,
MODEL XII-3-XB, MODEL XII-4-XB

Tools Required: Phillips screwdriver, ruler, and drill with 1/16" bit (tools not included)

Parts Included:

A 1pc Leg Frame

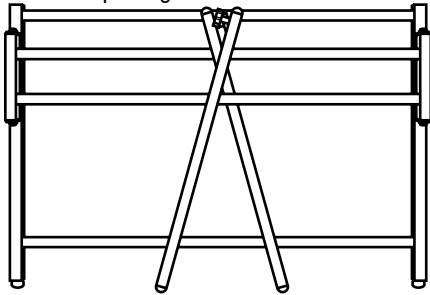

B 1pc Tabletop

(Shipped in separate box)

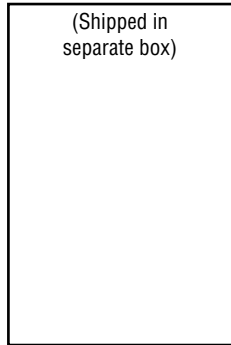

C 2pcs Rear Extension Tubes

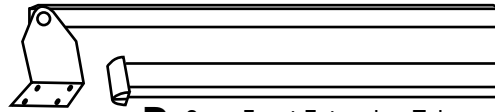

D 2pcs Front Extension Tubes

F 4pcs Height Adjustment Knobs

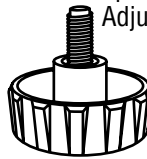

G 2pcs Front Guide Tracks

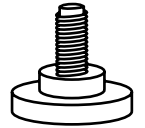

E 2pcs Floor Glides (Already installed into legs)

H 12pcs 1/2" Wood Screws

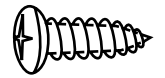

Assembled table

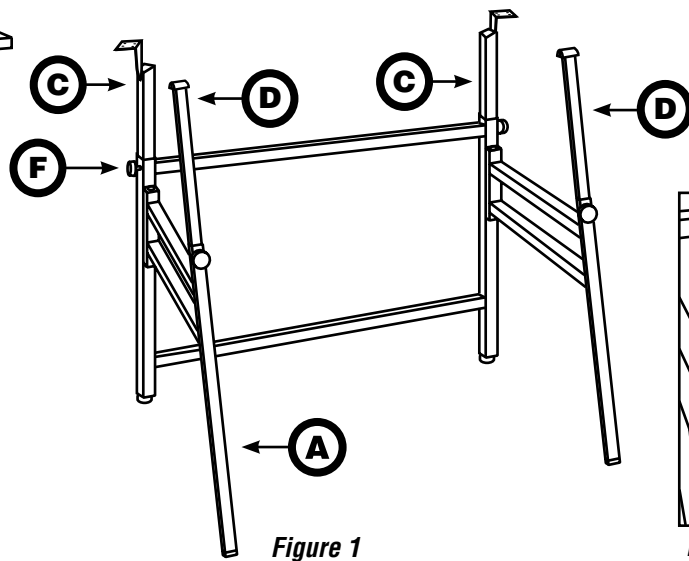

Figure 1

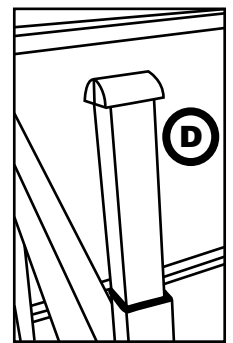

Figure 2

To Assemble:

Unpack parts and inspect to confirm that all are present.

- 1** Unfold leg frame (**A**). Insert rear extension tubes (**C**) into back tubes of leg frame with mounting brackets facing out. Slide tubes in as far as they will go and then loosely hand-tighten height adjustment knobs (**F**). See **Figure 1**.
- 2** Insert front extension tubes (**D**) into front tubes of leg frame with the curved black caps facing front and back. See **Figures 1 & 2**. Set each tube at a height of approximately 4" and then loosely hand-tighten height adjustment knobs.
- 3** Place tabletop (**B**) with preferred side down on a carpeted or protected floor to prevent scratching. Turn the assembled base frame upside down and place on tabletop with front guide tracks (**G**) placed (but not screwed in yet) under the front extension tubes. See **Figure 3**.

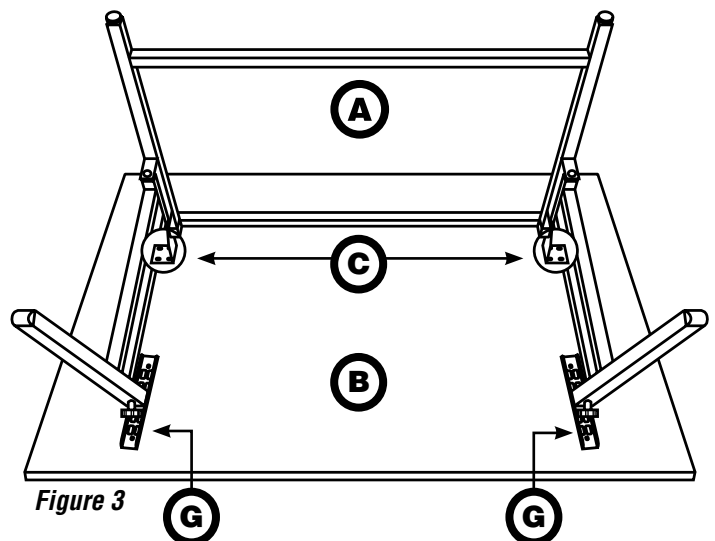
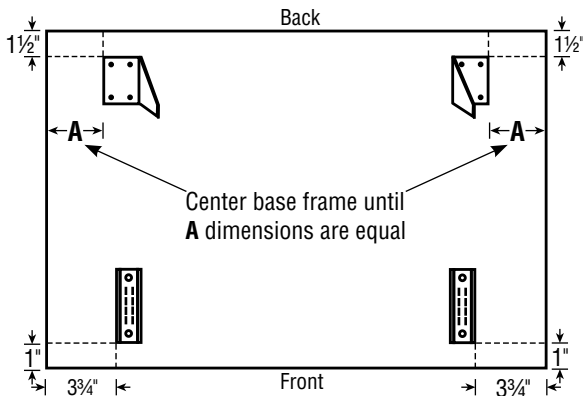

Figure 3



For 24" x 36" Tabletop



4 Position the frame and front guide tracks using the dimensions to the left, according to the size of your tabletop. Be sure to center the frame from left to right. Mark front guide track and rear extension tube bracket hole locations with a pencil or awl.

5 Using a 1/16" bit, drill pilot holes 1/4" deep only. Use care not to drill through the table top.

TIP Wrap masking tape 1/4" from drill bit end to determine drilling depth.

6 Attach rear extension tube brackets and front guide tracks to tabletop using 1/2" wood screws (**H**). See **Figures 4 & 5**. Tighten securely but use care not to strip.

7 Carefully return table to upright position. Adjust tabletop to desired height and angle using height adjustment knobs.

You're finished and your table is ready to use.

For 31" x 42" Tabletop

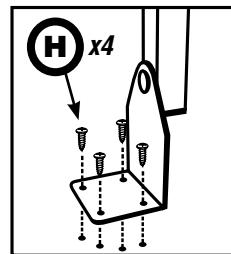
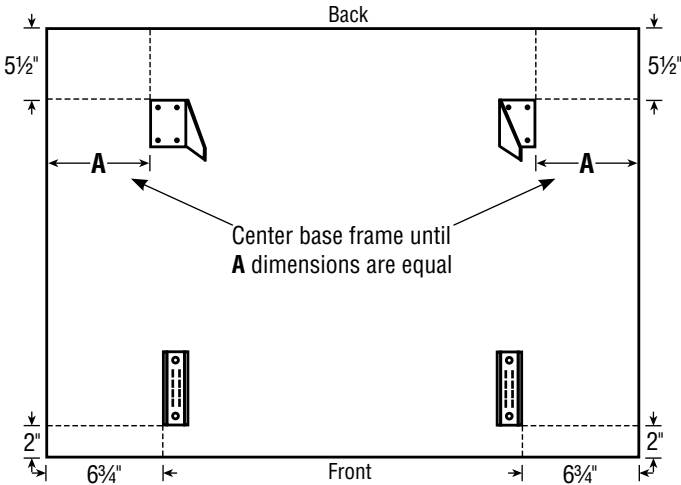

Figure 4

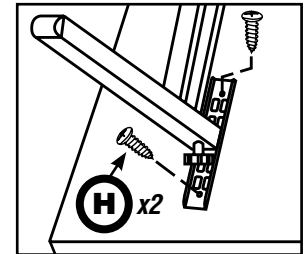
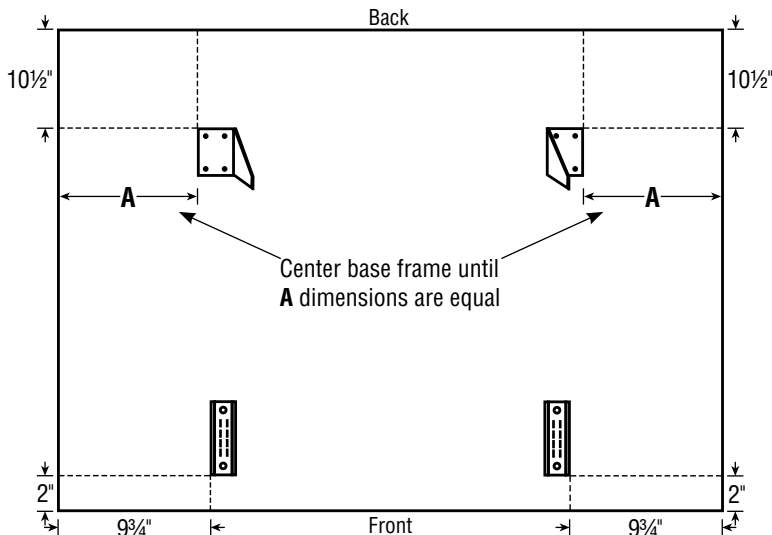

Figure 5

For 36" x 48" Tabletop



To Fold Table:

Drop all extension tubes down to their lowest positions. Lift the tabletop up until the front extension tubes disengage from the front guide tracks, then move the left leg frame in until it is flush against the rear frame assembly. Next, move the right leg frame in flush against the left leg frame. Gently lower the tabletop down flush against the folded legs. The table is now ready for storage.

